

CFS8720-S Cartridge



The CUNO® CFS8720-S cartridge offers the highest dirt loading capacity and lowest pressure drop capability in the CUNO Food Service range. Either as a single chlorine taste and odor reducing filter or in combination with the CUNO System ONE™ line of systems, the CFS8720-S cartridge offers the CUNO advantage for problem water.

The CFS8720-S incorporates a time released scale inhibitor and graded density prefiltration before a premium blend of high absorption granular activated carbon. Nothing surpasses this combination for dirt holding capacity and long life.

The CFS8720-S cartridge is designed for use in locations where standard or ultra-fine filtration gives less than normal life or in areas where ultra-fine filtration is not required.

Features like a built-in graded density prefilter, premium high absorption G.A.C., extended chlorine capacity, scale prevention and a strong cartridge body makes **the CUNO advantage clear.**

Features

- Premium graded density filtration for particle removal to 5 micron nominal.
- Chlorine reduction up to 4,800 gallons (18,170 liters).
- Low initial and sustainable differential pressure.
- FDA CFR-21 compliant materials.
- Time released scale inhibiting system.
- No activation required.**

Benefits

- Extended life in problem water supplies and longer life in normal water supplies.
- Reduces unwanted taste/odors and chlorine corrosion of metallic components.
- Protects sensitive equipment from low pressure shutdown.
- Only food grade material utilized throughout to meet food and potable water standards.
- Protects equipment against scale and down time.
- Cuts service time in half and assures cartridge will perform as expected.

Series 8000 Cartridges

CFS8720-S

Specifications:

Dimensions: 12-7/8" X 3-3/16"
(32.7 cm X 8.1 cm)

Service Flow Rate: 1.5 gpm (5.7 lpm)

Pressure: 125 psi (862 kPa)

Temperature: 100°F (38°C)

Capacity: 4,800 gallons (18,170 liters).

Efficiency: 5 micron

Cross Reference

CFS8720-S	CUNO Systems Series 6000 Heads Series 7000 Heads	May be used in place of CFS8812-S, CFS8112-S, CFS517LS
-----------	--	--

Installation Tips

- Check operating parameters of food service equipment before shutting off water supply.
- Check existing filter head for damage (do not install in damaged heads). Call your CUNO Food Service Distributor to size a new CUNO filter.
- For cold water use only.
- For commercial use only.

LIMITED ONE-YEAR WARRANTY

CUNO, Inc. warrants to the original purchaser-consumer that this Product is free of defects in materials and workmanship. Any defect, malfunction, or other failure of the product to conform to this Warranty will be remedied by CUNO.

This warranty, together with any and all warranties implied by law, shall be limited to a duration of one (1) year from the date of original purchase by the consumer.

This Warranty does not apply to defects that result from abuse, misuse, alteration or damage not caused by CUNO.

Distributed by:

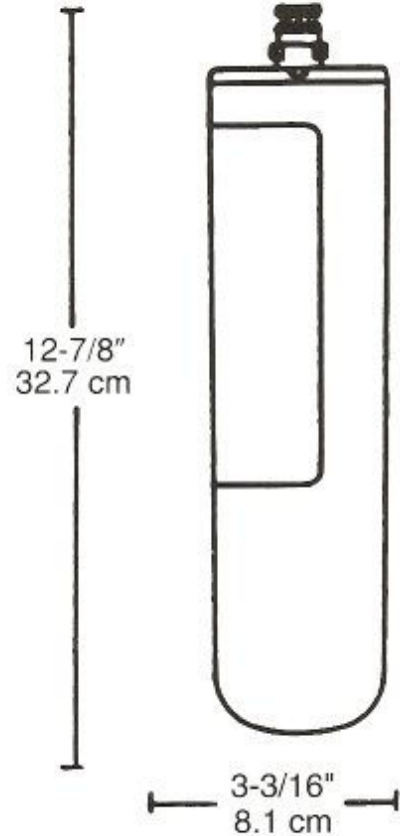

Made from FDA*
CFR-21 Compliant
Materials
*Food and Drug
Administration of USA

Do not use with water that is microbiologically unsafe or of unknown quality without adequate disinfection before or after the system.



The models CFS7720-S/CFS8720-S and CFS6720-S/CFS8720-S have been tested and certified by NSF International against ANSI/NSF Standard 42 for the Reduction of Chlorine, Taste/Odor (Class I) for 4,800 gallons (18,170 liters).